

THEME-3

Technical Education – An Indian Perspective

Addressing Engineering Graduate Competencies through Course Outcomes: Some Examples

B. Kanmani

*Department of Telecommunication Engineering, BMS College of Engineering, PB No 1908, Bangalore
E-mail: bkanmani.tce@bmsce.ac.in*

ABSTRACT

Outcomes Based Education (OBE) is focused on measuring the outcomes or skills gained by the student at the time of graduation and subsequent performance a few years after graduation. The entire focus on the Education System is student learning. The skills gained by the student at the time of graduation are defined through the Program Outcomes (POs), and the Program Specific Outcomes (PSOs), while the performance of the graduates a few years after graduation is described by the Program Educational Objectives (PEOs). The POs and PSOs are addressed through the Course Outcomes (COs), which represent the outcomes of various courses of the curriculum. Hence, it can be said that the COs form an essential constituent of the OBE system. While defining the CO is an important task, equally important is the assessments used to measure the CO. In this work we give sample COs to address a given attribute and list methods of developing the attribute through the assessments. While we need to develop both the PO and the PSO through the COs, in this work we focus on developing the POs, as these skills are common across all programs. Most of the COs mentioned are taken from our program.

Keywords: Course Outcomes, Program Outcomes, Assessments.

INTRODUCTION

Every course in the curriculum has about 4-6 COs, with each CO addressing one or more PO/PSO. The COs need to be assessable and measurable and they describe the Knowledge/ Skill/ Attitude acquired by the student at the end of the course. The COs are defined to develop an attribute or skill or competency in the student, through the Teaching- Learning-Process of the course. We cannot have more than one CO address the same attribute; i.e., we cannot have three outcomes of a single course address the 'design' attribute. On the other hand, we can have a single CO address more than one PO/PSO. There exists a need to develop every PO/PSO through more than one course. It is not possible to develop the essential attributes of the graduating engineer through introducing additional courses to develop a specific skill; for example: two courses to develop 'communication skill', two courses to develop 'professional ethics', two course to develop 'project management'. If this method is adopted, then the student will not have the knowledge component. Hence, it becomes essential to develop the attributes through the outcomes of existing courses. Given the content for a course, it is possible to define COs, the delivery methods and assessment tools such that they address the desired POs/PSOs. Hence the basic building blocks of an

OBE system are the Course Outcomes (COs) [1-5]. In this work, we present some examples of COs, together sample assessments/activities.

COURSE OUTCOMES

Some of the attributes like apply, design, solve can be assessed during conventional examinations. On the other hand attributes like professional ethics, communication skills, team work, can be developed through activities like oral presentation, a mini-project, a play, a debate, and may not be feasible for assessing in the conventional examination. These activities may be included in any course, and needs to be assessed through rubrics defined for the task. We now give some examples for the attribute being developed, together with sample assessment/activity.

Remember Skill

The remember skill is does not find emphasis by most Accreditation bodies, as this skill gets addressed through the development of other higher order skills. It involves the ability to recall from memory, and some of the key words associated with this attribute are: define, list, give example, comprehend, show, omit, match, who, what, when, where, name, label, etc. do not emphasize the development of this attribute, [6]. Although the development of this attribute is not emphasized, we continue to observe assessments that test this skill. We need to consciously reduce this component gradually, and definitely ensure that the complete assessment does not focus on just this skill.

<i>Course</i>	<i>Course Outcome</i>	<i>Assessment Examples</i>
Contiuous Time Signal Processing	Ability to define and understand continuous time signals and systems; their time and frequency domain representation	Define continuous time signals.
		List the different methods for representing continuous time LTI systems.
		What are equalizers? State their application

Apply Engineering Knowledge

The engineering graduate needs to have the ability to apply acquired knowledge of mathematics, science and engineering fundamentals to solve problems related to the engineering domain. The key

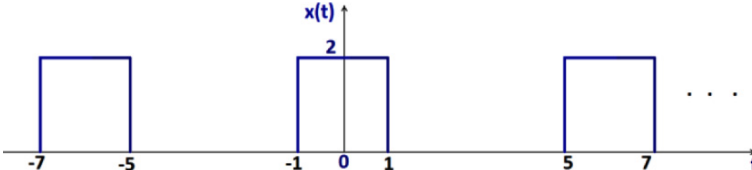
<i>Course</i>	<i>Course Outcome</i>	<i>Assessment Example</i>
Continuous Time Signal Processing	Ability to apply knowledge of mathematics to obtain the output for LTI systems	Obtain and sketch the output of an ideal LPF of cut-off 0.2 Hz, with input being the continuous time periodic signal given below
		
		Obtain and sketch the step response and frequency response of an LTI system with impulse response given by: $h(t) = 2 \exp(-2t)$. $u(t)$

words associated with the development of this attribute are: derive, solve, develop, build, organize, model, explain, etc [6]. This is an attribute to be developed and can be assessed through conventional examinations.

Problem Analysis

The ability to analyze systems, research literature to arrive at valid conclusions is another essential attribute in the engineering graduates. The key words associated with the development of this attribute are: analyze, conclude, classify, contrast, infer, distinguish, examine, inspect, categorize, compare, divide, examine, etc [6]. Through planned efforts we can design assessments that address this skill. This skill can be assessed through regular examinations or through some defined activities. Activities to include data analysis, to arrive at suitable conclusion, conducting surveys to categorize components/equipment based on features also address this attribute.

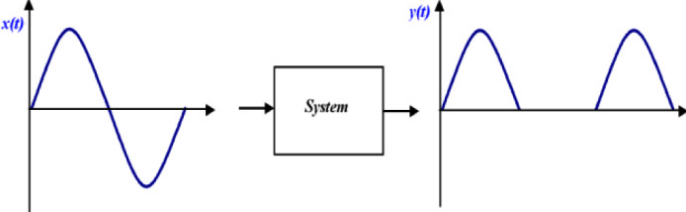
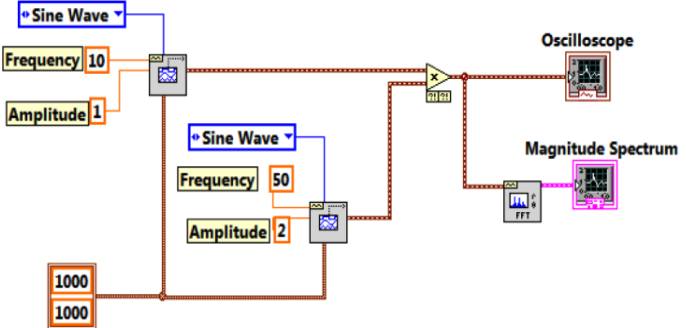
Course	Course Outcome	Assessment Example
Continuous Time Signal Processing	Ability to analyze given continuous time signals and systems	<p>Given below is the input-output of an electronic circuit analyse the system for linearity</p>  <p>Given the Block Diagram Panel of LabVIEW Code, sketch the corresponding result on the 'Oscilloscope' and the 'Magnitude Spectrum'. (Free hand sketch)</p> 

Design/Development of Solutions

The design attribute ensures the student has acquired the ability to arrive at suitable solutions for a given engineering problem. The key words associated with the development of this attribute are: design, build, maximize, minimize, develop, create, compile, formulate, improve, invent, modify, etc [6]. This is another attribute that can be assessed through conventional examinations, when the

problem statement is simple. However, true design problems have multiple solutions and the task is to select the right solution based on available constraints. It may be difficult to assess true design problems in conventional examinations purely because of the time constraint. If the available time to solve a design problem is enhanced, then development and assessment of this attribute becomes feasible. Assignments may be included to address this attribute.

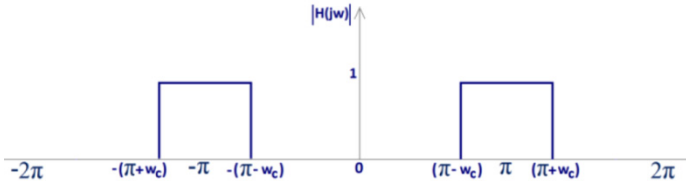
Course	Course Outcome	Assessment Example
Discrete Time signal processing	Ability to design discrete time systems that meet given specifications	Give ANY TWO valid designs of a digital filter to have the following frequency response, and recommend the best design with suitable justification. 

Conduct Investigations of Complex Problems

This attribute attempts to develop the ability to conduct research of available information/data to consolidate and arrive at valid conclusions. This attribute is not easy for assessment in conventional examinations, and needs to be assessed through other activities like: seminar presentation, report submission, literature search, a market survey.

Course	Course Outcome
Microcontrollers	Ability to perform a market survey, and arrive at the required microcontroller for solving the given problem statement
Project work	Ability to consolidate the literature search to formulate the problem for the project work

Modern Tool Usage

This attribute is an attempt to identify, list, select and apply the suitable engineering tool, to arrive at a valid solution(s) to an identified engineering problem. This attribute may be developed through suitable activity associated with a course [7]. It is to be observed that the use of modern tool may be addressed in laboratory sessions, or in typical class room examinations. It is also possible to develop design skill, team behaviour, analysis skill, communication skill, through carefully defined tasks used for the assessment of this attribute. Hence, assessment of this attribute is accompanied through the attainment of one or more other skills.

Course	Course Outcome	Group Activity / Assessment
Digital Communication	Ability to develop the Digital Communication Tool Box using a suitable engineering tool	To develop the Digital Communication Tool Box, using Multisim or LabVIEW or Matlab or Simulink or any other

The Engineer and Society

Apply reasoning informed by the contextual knowledge to assess societal, health, safety, legal, and cultural issues and the consequent responsibilities relevant to the professional engineering practice.

<i>Course</i>	<i>Course Outcome</i>
Computer Communication Networks	Ability to demonstrate compliance to the prescribed standards/safety norms through implementation of the identified engineering problem [8-10]

Concern for Environment

Understand the impact of the professional engineering solutions in societal and environmental contexts, and demonstrate the knowledge of need for sustainable development.

<i>Course</i>	<i>Course Outcome</i>
Analog Electronic Circuits	Ability to have an awareness of the hazards of electronic waste, [11,12]
Microwave and Radar	Ability to have an awareness of the established norms for transmission power levels through antennas [13-14]

Professional Ethics

We can identify TWO distinct components associated with developing Professional Ethics: (i) General professional behaviour, (ii) specific professional norms related to the program. The first component relates to general conduct, and is common to graduates from various programs. On the other hand, the second component is distinct to the program, and includes abiding by the recommendations of the established standards and norms of the program (as specified by professional bodies or the regulatory authorities). This attribute can be assessed through some activities like: debate, seminar, written presentation, play or any other.

<i>Course</i>	<i>Course Outcome</i>
Project Work	Ability to abide by the norms of professional ethics
Constitution of India and professional ethics	Ability to have an awareness of the fundamental rights of an Indian citizen [16]
Computer Communication Networks	Ability to have an awareness of the norms of E-mail communication as recommended by the Government [10]
Transmission Lines and antennas	Ability to have an awareness of the established norms for transmission power levels from antennas [13-15, 17, 18]

Individual and Team Work

Function effectively as an individual, and as a member or leader in diverse teams, and in multidisciplinary settings. Here it is essential to observe the performance of the student in assigned Group activities. Besides evaluation by the faculty, a form of peer evaluation may be included

(with a small weightage). Merely ensuring group activities does not lead to developing this attribute, unless process includes component to measure performance in a team.

<i>Course</i>	<i>Course Outcome</i>
Project Work/ Mini-Project	Ability to perform in the team, contribute to the team and mentor/lead the team

Developing Communication Skill

To ensure a successful professional career, there is a need to develop different types of communications skills [19]. It is possible to plan and embed these skills through the Outcomes of a course, and may be addressed through any Core Course of the program, with assessments that may include conduction of a QUIZ, or evaluation through suitable defined RUBRICS.

Skill	Course	Course Outcome
Reading Skill	Wireless Communication	Ability to read and comprehend research articles (IEEE publications) related to the course
Listening skill	Computer Communication Networks	Ability to listen and comprehend webinars/video lectures offered through the QEEE/NPTEL initiative [20,21]
Speaking skill	Op-amps & Linear ICs	Ability to make an Oral presentation/submit a video on assigned topics related to course
Writing skill	Project Work	Ability to engage in effective written communication through the one-page poster presentation of the work
Chat skill	Digital Signal Processing	Ability to engage in social networking activities related to the course (essential to have a suitable platform, for registered candidates of the course) [22]

Project Management and Finance

Our graduates need to be able to work successfully in teams and execute projects. Hence, project management concepts can be integrated with projects (or mini-projects) implemented as part of the curriculum. Multidisciplinary teams may be encouraged if possible. Most courses of the curriculum address the technical content, and has little emphasis on the financial component. It is essential to

<i>Course</i>	<i>Course Outcome</i>
Digital Communication	Ability to formulate, design, implement, demonstrate, analyze a mini- project related to the course
Project Work	Ability to prepare the Gantt Chart for scheduling the project work and designate responsibility of every member in the team
	Ability to perform the budget analysis of the project through the utilization of resources (finance, power, area, bandwidth, weight, size, any other)

embed this component in existing courses, through suitable outcomes or through expert lectures or through discussion of case studies. If the basic concepts of project management is introduced to the student during the third year, then one can ensure that the engineering project is implemented through applying the principles of project management.

Life-Long Learning

We consider this attribute as the ability to engage in 'self-study', or 'independent- study', so that it eventually leads to 'life-long-learning' [23]. Some methods of introducing the self-study or the independent study competency are: (i) listening to a webinar, (ii) learning to use a modern tool, (iii) reading the technical manual leading to the effective usage of the laboratory equipment, (iv) reading research article(s), (v) watching a video, (vi) update on the standards/policies, or (vii) taking an on-line course. The list is not exhaustive, and it is possible to include additional methods, and all these methods can be included in any course, and can be evaluated by defined rubrics.

<i>Course</i>	<i>Course Outcome</i>
Computer Communication Networks	Ability to engage in independent study through listening to suggested webinars/video lectures offered through the QEEE/NPTEL initiative [20,21]
Op-amps & Linear ICs	Ability to engage in independent study to make an Oral presentation/submit a video on assigned topics related to course

CONCLUSIONS

In this work we have presented some Course Outcomes, together with possible assessments/activities. The methods suggested can be introduced in any course. Most of the attributes addressed through the COs, can be introduced in any course. When the COs are well defined and assessed, it leads to improved quality in the graduating engineer. All examples presented are taken from courses offered by our program.

ACKNOWLEDGEMENTS

The author acknowledges the support and guidance extended by Dr K Mallikharjuna Babu, Principal, BMS College of Engineering. The support and cooperation extended by all faculty of the Telecommunication Engineering department, for introducing continuous improvements in the teaching-learning process is sincerely appreciated and acknowledged.

REFERENCES

- [1] <http://www.nbaind.org/Files/General%20Manual%20of%20Accreditation.pdf>
- [2] <http://www.abet.org/changed-definitions-for-program-educational-objectives>
- [3] <http://www.njrao.org/attachments/article/51/Competencies.pdf>
- [4] B Kanmani and Mallikharjuna Babu,'Defining Course Outcomes: An example', 2nd World Summit on Accreditation: International Recognition of Educational Qualifications, Conducted by NBA, 8th to 10th March 2014, at Hotel Ashok, New Delhi.

- [5] B. Kanmani, K. Mallikharjuna Babu, 'Continuous Improvements in Teaching-learning-process in Outcomes Based Education', *Journal of Engineering Education Transformations*, Vol. 28, No. 2 & 3, Oct. 2014 & Jan. 2015, ISSN 2349-2473, DOI: 10.16920/ijerit/2015/v28i2&3/56661
- [6] http://www.apu.edu/live_data/files/333/blooms_taxonomy_action_verbs.pdf
- [7] B. Kanmani, Shreenivas B, Prasanna Kumar MK, 'Introducing Modern Engineering Tool in Engineering Education: An Example', *IEEE 3rd International Conference on MOOCs, Innovation and Technology in Education (MITE)*, pp 388 – 391, Amritsar, 1–2 December, 2015
- [8] <https://www.itu.int/en/Pages/default.aspx>
- [9] <http://iee802.org>
- [10] <http://www.nic.in/services/e-Governance%20Standards>
- [11] <http://www.deity.gov.in>
- [12] <http://www.cseindia.org/content/how-dispose-e-waste>
- [13] <http://emfindia.com/HumanExposureStandards.aspx>
- [14] <http://www.who.int/peh-emf/standards/en>
- [15] <http://www.who.int/peh-emf/standards/en>
- [16] <http://india.gov.in/my-government/constitution-india/constitution-india-full-text>
- [17] <http://www.ddindia.gov.in/Pages/Home.aspx>
- [18] <http://allindiaradio.gov.in/Default.aspx>
- [19] Kanmani, B ; Babu, K Mallikharjuna, 'Introducing communication skills as an assessment tool in a course', 2014 IEEE International Conference on MOOC, Innovation and Technology in Education (MITE), Patiala, December 19–20, 2014, DOI: 10.1109/MITE.2014.7020266
- [20] <http://pilot.edureform.iitm.ac.in>
- [21] <http://www.nptel.ac.in>
- [22] <http://wiksateweb.cloudapp.net>
- [23] B Kanmani and Mallikharjuna Babu, 'Introducing Life-Long Learning in Engineering Education', *IEEE 3rd International Conference on MOOCs, Innovation and Technology in Education (MITE)*, Amritsar, 1–2 December, 2015.

B. Kanmani

Department of Telecommunication Engineering, BMS College of Engineering, PB No 1908, Bangalore



B. Kanmani, obtained her Bachelors in Electronics and Communication Engineering from Nagarajuna University in 1987, M.Tech. degree in Digital communication from Indian Institute of Technology, Kanpur in 1990, and PhD from the Indian Institute of Science Bangalore (IISc) in the year 2006. She has been with BMS College of Engineering, Bangalore, since 1995. Currently serving as Professor and Head, department of Telecommunication Engineering, she teaches under-graduate courses on Analog Signal Processing, Digital Signal Processing, Analog Communication and Digital Communication. She has steered the department to effective implementation of Outcomes Based Education. Her prior employment as a teaching faculty was with Thadomal Shahani College of Engineering (Mumbai) and KL College of Engineering (Guntur). She is Senior Member IEEE, and Life Member ISTE.